

# Single Phase All-in-one RESS Inspiration-S

# User Manual



# Revision Table

No	Version	Revised by	Content	Revision Date
1	Rev1.0	Hunter.LI	First release	2023.04.19
2	Rev1.1	Hunter.Li	Add note at page14	2023-9-06
3				
4				
5				
6				



## Content

1 Overview .....	- 1 -
1.1 Application Scope .....	- 1 -
1.2 Applicable People .....	- 1 -
1.3 User Manual .....	- 1 -
1.4 Disclaimers .....	- 1 -
2 Product description .....	- 2 -
3 Safety Instructions .....	- 4 -
3.1 Label Description .....	- 4 -
3.2 Installation Tools .....	- 4 -
3.3 Attention Items .....	- 5 -
4 Main Components .....	- 7 -
5 Product Description .....	9
5.1 Product Introduction .....	9
5.2 System Specification .....	9
6 Module Description .....	10
6.1 Module Specification .....	10
6.2 Illustration and Front Panel Description .....	11
6.3 VLES5000VS ID Setting Description .....	14
7 System Installation .....	14
7.1 Handling, Transportation, Storage .....	15
7.2 Open-box Inspection .....	16
7.3 Mechanical Installation .....	16
7.4 Electrical Installation .....	20
7.5 System Starting Up .....	21
8 Maintenance .....	23
8.1 Common Faults (Phenomenon) and Solutions .....	23
8.2 Daily Maintenance .....	24
9 Cautions and Warranty .....	- 25 -
9.1 Cautions .....	- 25 -
9.2 Description of Warranty .....	- 25 -



## 1 Overview

### 1.1 Application Scope

This manual introduces Single Phase All-in-one RESS products, including product specifications, operation specifications, product maintenance and other related information. For details on the operation, installation and use of the product, please refer to this user manual.

### 1.2 Applicable People

This manual is used for professional and technical staff who install, operate and maintain the batteries, as well as for the end-users who may need to view the relevant technical parameters. Anyone who operates must be qualified for electrical work.

### 1.3 User Manual

Before you operate Single Phase All-in-one RESS, you should be better trained and read the manual carefully, to ensure that the person using the product is fully understood. Remove any possible metallic shorting risks from jewelry, watches, pens, metal bars and frames. After reading, please keep it in a safe place for future reference.

### 1.4 Disclaimers

Failure to operate this product correctly may result in serious injury to yourself or others, or damage to the product or property. Once used, you will be deemed to have understood, acknowledged and accepted all the terms and contents in this document. Users undertake to be responsible for their own actions and all the consequences arising therefrom. The company shall not be liable for all damages caused by the user's failure in accordance with the provisions of this document and the user manual. The content of this manual will be constantly updated and revised, and update, revision or termination without prior notice. So please visit our official website or obtain the latest product manual through your local distributors.

## 2 Product description

Lithium-ion batteries are a new generation of green energy batteries. In recent years, with the rapid development of lithium-ion battery technology, the pace of lithium-ion batteries to replace traditional lead-acid batteries is also gradually accelerating in various power fields.

Single Phase All-in-one RESS product incorporates an integrated design, integrated installation and boasts a protection level of up to IP65, which is mainly used for household photovoltaic systems. It integrates a 5KW (LXP-5K hybrid) hybrid inverter and 51.2V/100Ah LFP battery pack. The battery pack has a modular, expandable design, enabling flexible power configuration up to 5KWh to 20KWh, and the hybrid inverter power supports 5KW. The product supports power grid, photovoltaic and battery access at the same time, and has the function of off-grid operation. The system has the advantages of high energy density, long cycle life and high compatibility.

<b>PV Input</b>	
Starting voltage	140VDC
Rated voltage	360V
MPPT voltage operating range	120-500V
Maximum input power	8000W
Maximum input voltage	550VDC
Maximum input current	13A
Maximum short circuit current	13.7A
<b>Battery input</b>	
Battery type	LFP battery
Battery capacity	100Ah
Nominal voltage	51.2V
Maximum charging voltage	57.6V
End-off voltage	44.8V
Maximum charging current	100A (recommended 50A)
Maximum discharge current	100A
Communications	CAN (communicates with inverter)/RS485
<b>AC input and output (power grid)</b>	
Maximum grid input power	5000VA













Maximum grid input current	25A
Rated output power	5000W
Maximum output power	5000VA
Rated output current	21.7A
Rated output voltage	230V
AC voltage range	180 - 270VAC
Total current harmonics (THDI)	<3% (rated power)
<b>Emergency output (battery)</b>	
UPS maximum power output	3600W
UPS nominal output power	3000W
Maximum output current	25A
Rated output voltage	230VAC
Output frequency	50/60Hz
Total voltage harmonics (THDU)	<5%
Off-grid switching time	<20mS
Efficiency	
European efficiency	97.5%
Maximum efficiency	97.9%
Battery charge/Discharge efficiency	94.5%
<b>System parameters</b>	
System size [W/H/D](mm)	674*180*1810mm
Operating temperature range [°C]	0~+55 (derated at 45°C)
Storage temperature [°C]	-20~+60
Store relative humidity	5%~90% (no condensation)
Altitude [m]	<2000
Protection level	IP65
Display	LCD/APP
Cooling mode	Natural heat dissipation
Inverter topology	non-isolation
Installation mode	Floor type

## 3 Safety Instructions

### 3.1 Label Description











In order to ensure the user's personal safety when using this product, this manual provides relevant identification information and uses appropriate symbols to alert the user, who should carefully read the following list of symbols used in this manual.

Table 3-1 Label Description

	Potentially low risk: may result in mild or moderate impairment if not avoided
	High Risk: May result in serious injury or death if not avoided
	The battery terminals must be disconnected before commencing on the battery
	The battery could explode and/or be severely damaged if dropped or crushed
	The battery may explode if exposed to open flames or other extreme sources of heat
	Grounding: The system must be firmly grounded for operator safety
	This side should be up
	Handle with care to avoid damage
	Keep dry
	Keep the battery away from kids
	Do not short circuit
	Do not reverse connection between the positive and negative
	Please read the instructions in the operation manual

### 3.2 Installation Tools

Table 3-2 Installation Tools Sheet

Tools	Multi-meter 	Protective gloves 	Insulated anti-smashing shoes 
	Protective suit 	Safety glasses 	ESD wrist strap 
Installation Tools	Electric screwdriver 	Cross screwdriver 	Socket spanner 
	Slotted screwdriver 	Wire stripper 	

## 3.3 Attention Items

### 3.3.1 Manual Custody

This manual contains important information about the Single Phase All-in-one RESS products. A careful reading of this manual will help you become familiar with this product, and this manual should be kept in a safe place so that it can be easily accessed by maintenance personnel at any time when needed.

### 3.3.2 Product Identity Protection

Warning labels, back panels and front doors of the cabinet contain important and safety protection information and are strictly forbidden to be torn and damaged.

### 3.3.3 Operator Requirements

Only trained and qualified professionals should perform various operations on the product: the product operator should be fully familiar with the product's system components and operating principles, as well as understand the product's user manual.

### 3.3.4 Safety Warning

 During the installation, daily maintenance, overhaul and other operations of Single Phase

All-in-one RESS products, the following conventions should be observed in order to prevent the accidental operation, proximity or occurrence of accidents by unrelated personnel: the front and rear switches of the products should be clearly marked to prevent accidents caused by wrong switches; warning signs or safety warning belts should be set near the operation area to prevent the proximity of unrelated personnel.

### **3.3.5 Electric Measurement**

 Due to the high voltage of the battery that may endanger personal safety, accidental contact may cause serious injury, so when you need to perform measurement operations, please take good insulation protection (such as insulating gloves).

### **3.3.6 Measuring Instrument**

 In order to ensure that the electrical installation meets the requirements, please use the relevant electrical measuring equipment, such as multi-meter, power meters, etc.

### **3.3.7 Maintenance**

 During maintenance and repair operations, it should be ensured that the energy storage battery cabinet is not accidentally charged; a multi-meter, should be used to ensure that there is no electricity in the energy storage battery cabinet; insulating materials should be used to insulate the possible electrical parts of the system; ensure that the system has necessary grounding connections.

## 4 Main Components

The core components of the Single Phase All-in-one RESS products are shown in Table 4-1 below:

Table 4-1 Main Components Sheet

No	Item	Picture
1	Hybrid Inverter (LXP-5K hybrid)	<p>Technical drawings of the Hybrid Inverter (LXP-5K hybrid) showing front, side, and rear views. Dimensions are indicated: 182mm height, 570mm width, and 455mm depth.</p>
2	Battery Module (51.2V100Ah)	<p>Technical drawings of the Battery Module (51.2V100Ah) showing front, side, and rear views. Dimensions are indicated: 570mm width, 420mm height, and 170mm depth.</p>
3	Mounting Base	<p>Technical drawings of the Mounting Base showing side and front views. Dimensions are indicated: 50mm height, 674mm length, and 170mm width.</p>

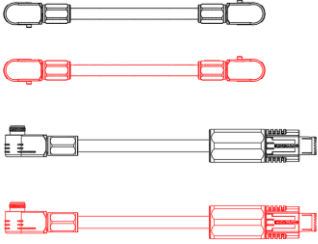
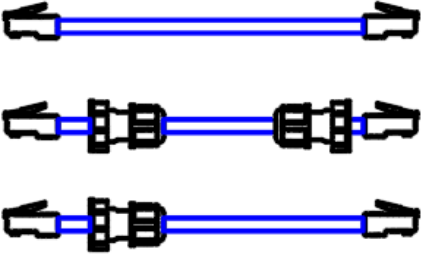
4	Power Cable	
5	Communication Cable	

## 5 Product Description

### 5.1 Product Introduction

Single Phase All-in-one RESS products are modular products designed for energy storage applications, which are widely used in small and medium-sized energy storage systems. Each product consists of a hybrid inverter and battery modules, with single modules comprising cells, BMS, and shell. The BMS within each module has independent voltage, current, temperature detection and protection functions.

### 5.2 System Specification

Figure 5-1 Hybrid Inverter Module

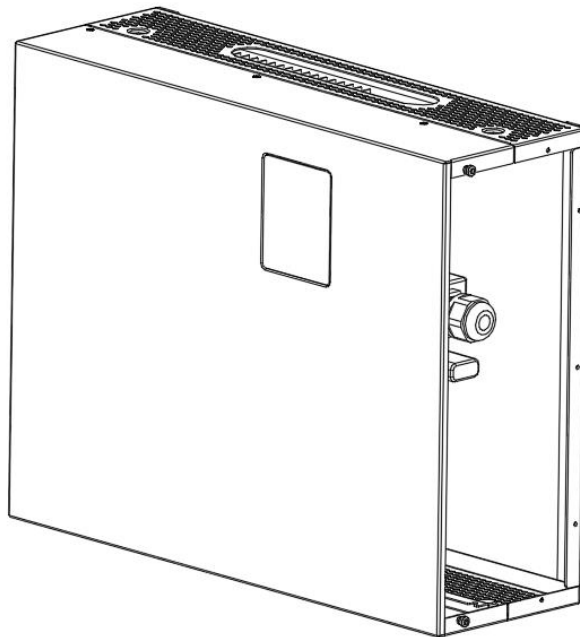

Figure 5-2 Low-volt Stacked Module

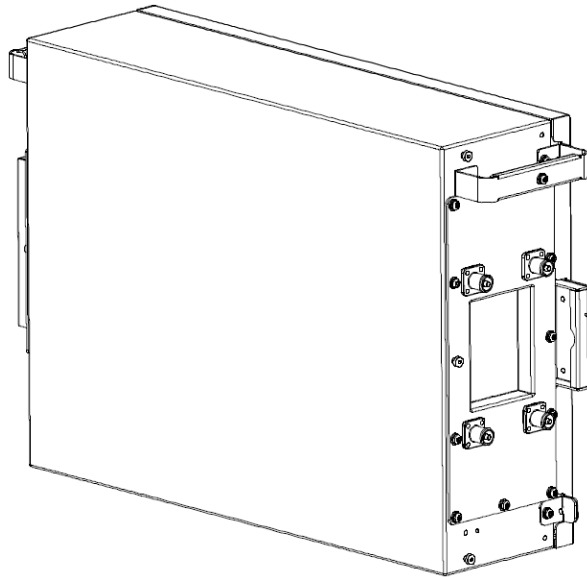
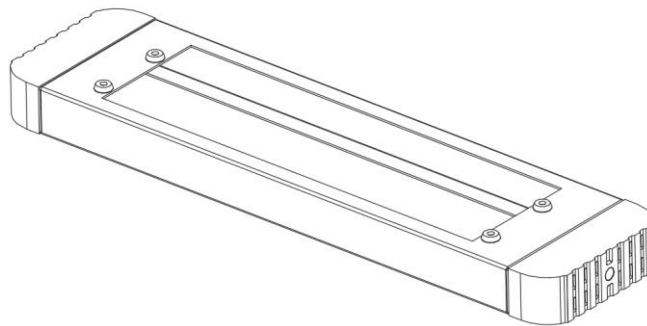

Figure 5-3 Mounting Base



## 6 Module Description

### 6.1 Module Specification

A newly designed solar and energy storage hybrid inverter, installed in on-grid solar, off-grid solar and back-up systems. The hybrid inverter enables a programmable and schedule smart solar energy storage system to help increase your solar energy self-consumption rate, protect your home appliances from grid outage, and balance your energy usage strategy to save energy bill.

Table 6-1 Hybrid Inverter Module Specification

Type	Voltage	Capacity	Battery	Width	Depth	Height	Weight
LXP-5K hybrid	230V	5KW	51.2V	570mm	180mm	420mm	20±2kg

VLES stacked vertical batteries are made of lithium iron phosphate battery modules with the highest safety performance. The battery modules are available in 51.2V100Ah. The following table describes related parameters.

Table 6-2 ZLES 51.2V Module Specification

Type	Voltage	Capacity	Energy	Width	Depth	Height	Weight
VLES5000VS	51.2	100Ah	5120Wh	570mm	170mm	420mm	53±2kg

## 6.2 Illustration and Front Panel Description

### 6.2.1 Hybrid Inverter Appearance & Dimension Schematic

Figure 6-1 Hybrid Inverter (LXP-5K hybrid) Appearance & Dimension Drawing

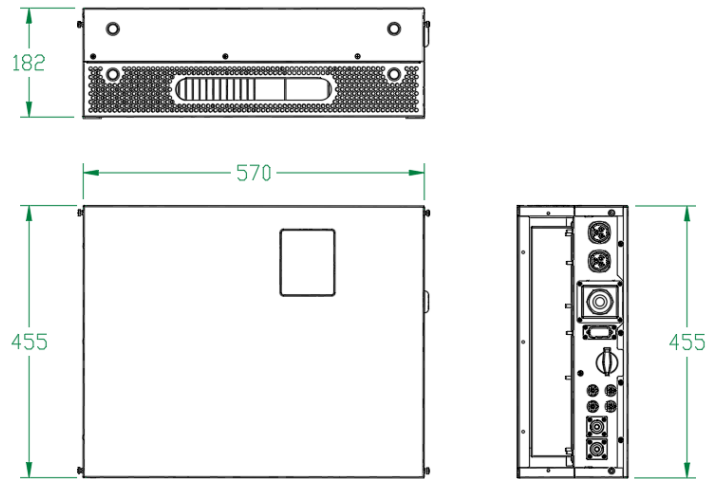

## 6.2.2 VLES5000VS Appearance & Dimension Schematic

Figure 6-2 VLES5000VS Appearance & Dimension Drawing

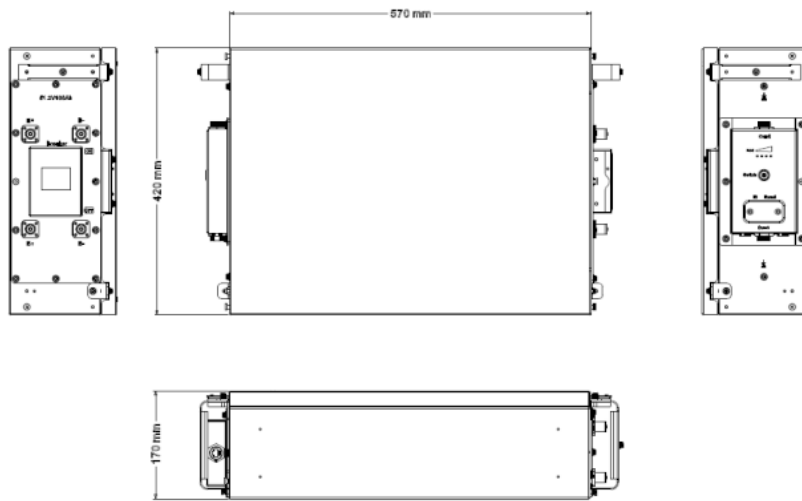

## 6.2.3 Hybrid Inverter Side View

Figure 6-3 Hybrid Inverter Side Panel Diagram

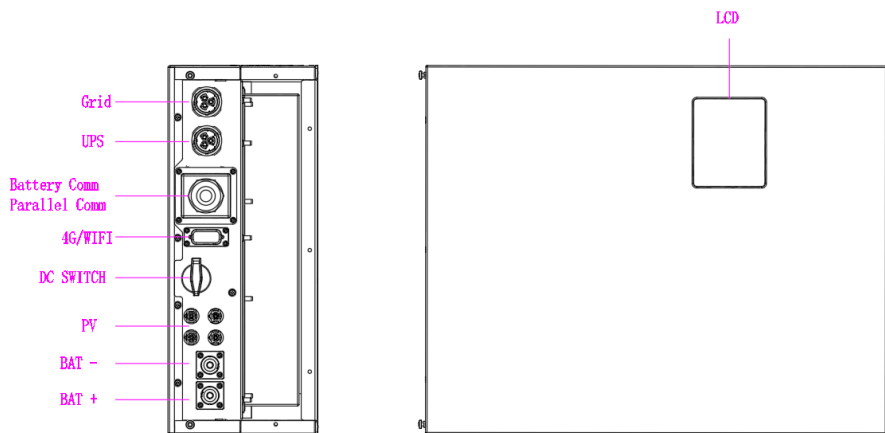

## 6.2.4 VLES5000VS Side View

Figure 6-4 VLES5000VS Side Panel Diagram

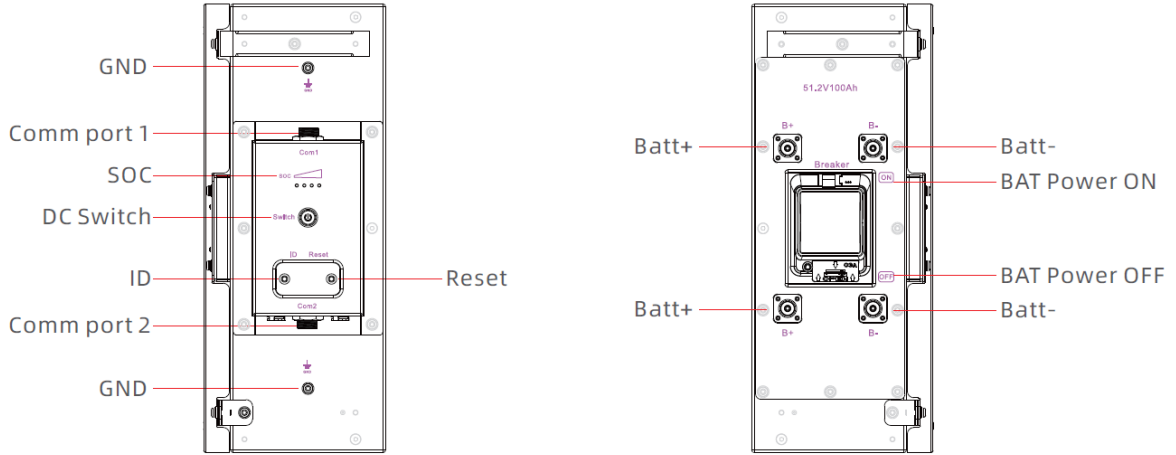
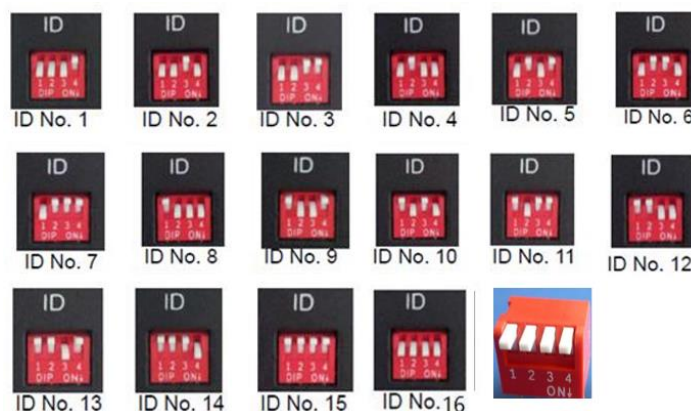

Table 6-3 VLES5000VS Side Interface Description

No.	Item	Function Description	Remarks
1	Batt+	Battery positive	
2	Batt-	Battery negative	
3	Batt Power	Power output switch	
4	GND	Ground point	
5	Comm port 1	Communication port	
6	Comm port 2	Communication port	
7	SOC	SOC Led display	
8	DC Switch	Battery switch	
9	ID	Battery address	
10	Reset	Reset button	

## 6.3 VLES5000VS ID Setting Description

Figure 6-3 ID Dialing Code Address Assignment Instructions



ID code bits corresponds to binary digits, down represents "ON", up represents "OFF", the right side of the code bit is the low bit, the left side is the high bit, the code range is 1~16.

NOTE: The battery pack ID connected to the hybrid inverter must be set to ID1, indicating that it is the host, the other battery packs need be in sequence set to ID2.ID3.ID4.ID5...

## 7 System Installation

### 7.1 Handling, Transportation, Storage

#### 7.1.1 Handling

 Rough handling practices may cause short circuit or damage to the battery pack, resulting in battery leakage or fire. Forklifts or carts should be used for handling, and materials transported should not exceed the width and height of aisles and doors, and should be transported at a moderate speed. Avoid the phenomenon of inverted and laminated battery packs when unloading.

#### 7.1.2 Transportation



 Due to the heavy weight of the battery module, in order to guarantee safety, it is recommended to use a forklift that meets the requirements for moving and transporting, and should avoid dropping and throwing; the equipment should be prevented from collision and strong vibration during transportation.

Figure 7-1 Handling tool diagram







#### 7.1.3 Storage

 Short-term storage (within 3 months): If the battery is not used in a short period of time, the battery can be fully charged and stored in a dry, cool, non-corrosive gas, temperature 10-45°C, relative humidity 60±30%, no strong electromagnetic fields and in direct sunlight.

 Long-term storage (over 3 months): If the battery is not used for more than 3 months, keep the battery SOC at 50%~70%, store it in a dry, cool, non-corrosive gas, temperature 20-35 °C, relative humidity 50 ± 15 %, in an environment without strong electromagnetic fields and direct sunlight, and ensure to charge once every 6 months to avoid irreversible capacity loss caused by long-term storage.

## 7.2 Open-box Inspection

Table 7-1 Unpacking Tools Sheet

Item	Tools		
Tools	Slotted screwdriver 	Protective gloves 	Stripper 
	Hammer 		

 Single Phase All-in-one RESS products have been strictly tested and tested before leaving the factory. Please sign for them after inspection. If the product is damaged, please contact the local distributor. Please open the box to check: whether the outer packaging is intact or damaged; whether the internal equipment is damaged.

## 7.3 Mechanical Installation

### 7.3.1 Installation Requirements

The installation position of the battery cabinet has a direct impact on its safety, service life and performance. It should ensure that the wiring of the system is convenient, easy to maintain and operate, and should avoid placing the battery mounting base in a high temperature and high humidity environment. To ensure the flatness of installation floor. As shown in the following figure.

Figure 7-2 Installation Diagram

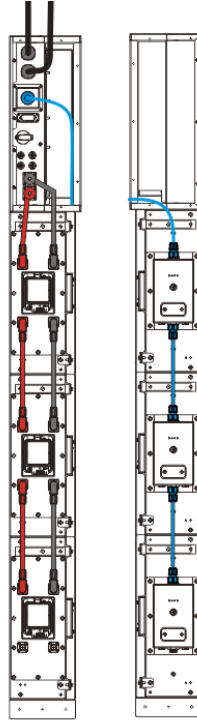

### 7.3.2 Mounting Base Installation

Remove the mounting base from the box and place it on flat ground. Our special construction design eliminates the need for screws to secure the base to the floor.

Figure 7-3 Mounting Base Installation

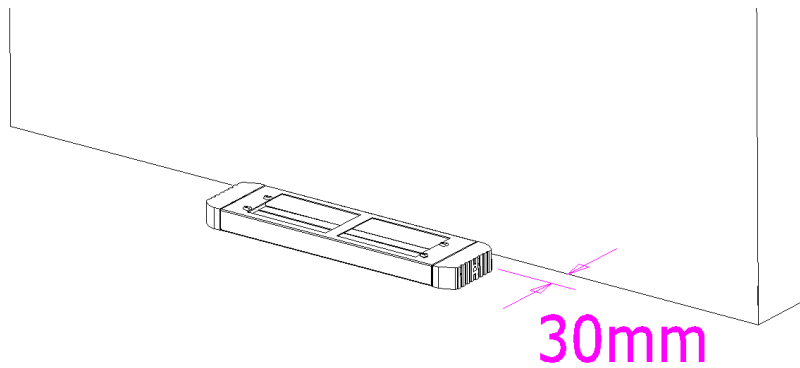

### 7.3.3 Battery Module Installation



According to the actual situation of the installation site, use manual or machine to carry the module; it is recommended that at least two people lift it together and wear anti-smashing shoes and non-slip gloves during installation.

Figure 7-4 Battery Module Installation diagram

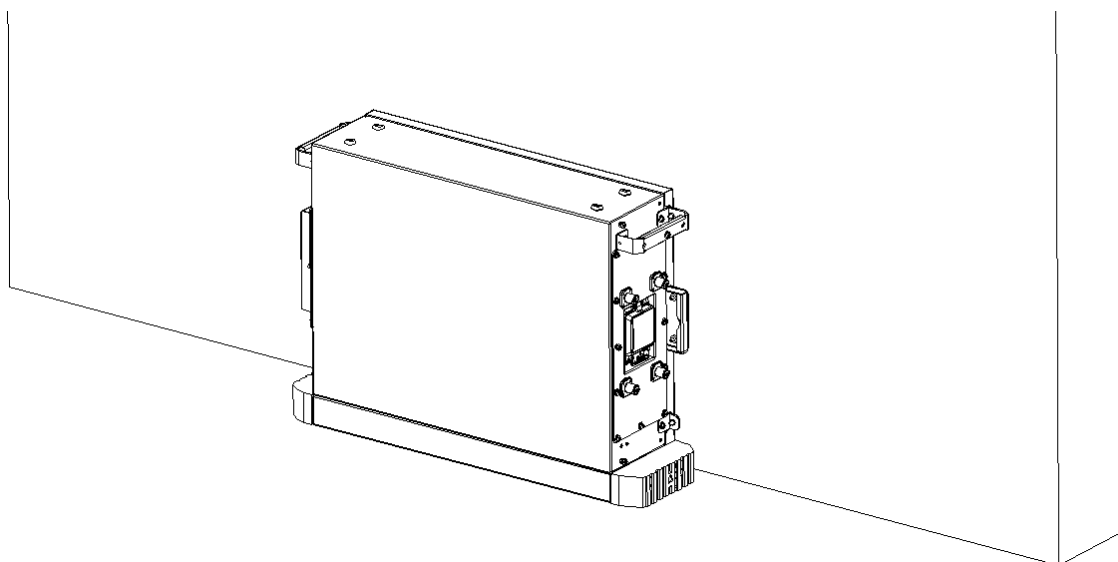

### 7.3.4 Combiner box Installation

While the low-volt battery module installation is finished, the final step is to install the Hybrid inverter. Place the Hybrid inverter at the top of the entire system, and make sure the fixing holes are aligned, then fasten it firmly with the battery module below with the quick lock pin.

Figure 7-5 Single Phase All-in-one Installation

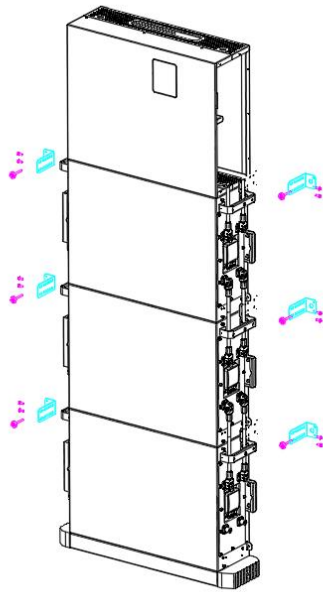

### 7.3.5 System Fixed Installation

 Considering that our mounting base adopts non-traditional screw fixing method, so we need to install a fixed mounting ear on the wall to ensure the stability of the battery system after the combiner or high-volt box installation is done. The battery system is at risk of tipping if not handled properly.

Figure 7-6 Mounting Lug Installation







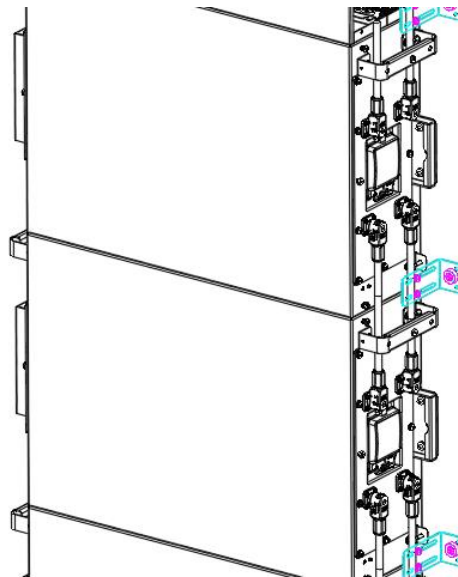

## 7.4 Electrical Installation

### 7.4.1 Tools Introduction

The following tools are required for electrical connection, as shown in Table 7-2:

Table 7-2 Electrical Installation Tools Diagram

Item	Tools		
Tools	Multi-meter 	Protective gloves 	Screwdriver 
	Electric batch 	Cross screwdriver 	Socket wrench 

### 7.4.2 System Cable Connection

Figure 7-7 Single Phase All-in-one System Connection Schematic

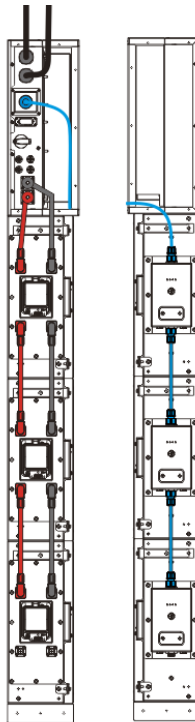

 (1) Grounding. One end of the grounding cable (PVC 25mm<sup>2</sup>) is screwed to the grounding hole at the end of the chassis (M5), and the other end is connected to the grounding copper strip to ensure a solid connection.

 (2) Communication cable installation. Finally, connect the RS485/CAN interface of the No.1

battery to the inverter via communication cable.

 (3) Power cable installation. Use the power cable to connect each battery in parallel as the above picture shows. Avoid short circuit and reverse connection of positive and negative terminal.

 (4) Connect the equipment. Make sure the battery and device are powered off before connecting. Clearly identify the location of the positive and negative terminals of the system, red to the positive terminal, black to the negative terminal, to ensure no connection errors.

## 7.4.3 Side Panel Installation

After all wiring harnesses are installed (power lines, communication lines), use power tools to complete the side panel installation.

Figure 7-8 Side Panel Installation

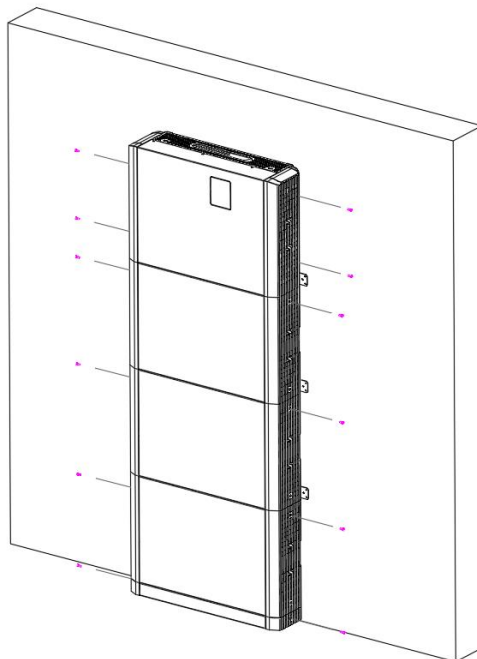

## 7.5 System Starting Up

### 7.5.1 Start Up Checking

 After installation or maintenance, Single Phase All-in-one System needs to be started up. Before starting up, please check the following precautions carefully to make sure there are no errors.

All electrical connections must be made in accordance with the electrical diagrams in the manual; the DC combiner box must be open; the cables are properly distributed, without mechanical damage, and connected and fastened correctly; the internal protection devices in the combiner box must be firmly installed; No excess parts or conductive material remains.

## 7.5.2 System Turn On

 After completing the above steps, press the ON/OFF switch on the control panel to turn on the machine, then turn on the miniature circuit breaker and turn on the power of the whole system to complete the installation.

System turns on step:

- (1) Double check all cables are connected correctly, and make sure the grounding is proper.
- (2) Turn on the switch at inverter's battery side or between inverter and battery.
- (3) Turn on the battery system.
- (4) Turn on the inverter.

## 7.5.3 System Turn off

When failure or before service, must turn off the battery system, the procedure to switch it off is:

- (1) Switch off the Hybrid inverter;
- (2) Switch off the battery;
- (3) Switch off the air switch between the battery and the inverter if there is any.

## 7.5.4 System Charge

 When the battery system is transported or stored for a long time, the battery SOH may be low due to self-discharge of the cells and system consumption, and the lithium battery needs to be charged after normal start-up and before use.

## 8 Maintenance

### 8.1 Common Faults (Phenomenon) and Solutions

Common faults and solutions are shown in table 8-1.



Table 8-1 Common Faults (Phenomenon) and Solutions

NO.	Fault phenomenon	Analysis	Solution
1	Communication failure with inverter	Communication port connect error or battery ID setting error	Check communication connection or ID settings
2	No DC output	Not close breaker or low voltage	Close breaker or charge the battery
3	Power supply time is too short	Battery capacity lack or not fully charged	Maintenance or replacement
4	Battery can't be fully charged	Power system DC output voltage falls below the minimum charge voltage	Regulating DC output voltage of power supply to battery suitable charging voltage
5	ALM LED always lights	Power line connection short circuit	Disconnect the power cable and check all cables
6	The battery output voltage is unstable	Battery management system do not operate normally	Press the reset button to reset the system, then reboot the system
7	ALM LED flash 20 times and SOC1 LED on	Unbalance voltage with cell	Examine/balance the cell
8	ALM LED flash 20 times and SOC2 LED on	Unbalance temperature	Replace temperature sensor cable
9	ALM LED flash 20 times and SOC3/4 LED on	BMS damaged	Replace BMS
10	Different SOC value of batteries in parallel	Normal phenomenon	No operation

## 8.2 Daily Maintenance

Routine maintenance items are shown in Table 8-2 below.

Table 8-2 Routine Maintenance Items

Item	Maintenance Method	Maintenance intervals
<p>Power Cables</p> 	<ol style="list-style-type: none"> <li>1. check whether there is mechanical damage to the power cable and whether the terminal insulation sleeve has fallen off; if there is such a phenomenon, please turn off the machine and carry out maintenance or replacement.</li> <li>2. check whether the power cable is loose; if there is any sign of looseness, please use a standard torque wrench to tighten it.</li> <li>3. check the system for loose screws or discoloration of the copper bus bar; if the screws are loose, please tighten them with a standard torque wrench; if the copper bus bar is discolored, please contact the manufacturer for after-sales replacement.</li> </ol>	<p>Once every 6 month</p>
<p>Communication Cables</p> 	<ol style="list-style-type: none"> <li>1. check whether the parallel communication cable terminal is loose, if it is loose, re-tighten it.</li> <li>2. check whether the color of the communication cable has obvious discoloration, if discoloration, please shut down the machine to replace the communication cable</li> </ol>	<p>Once a year</p>
<p>Cleanliness</p>	<p>Check the cleanliness of the front battery module &amp; combiner box, if there is obvious dust, please clean up in time.</p>	<p>Once 6-12 month</p>
<p>System Running Status</p> 	<ol style="list-style-type: none"> <li>1. check if all parameters are normal when the system is running (system voltage, current, temperature, etc.)</li> <li>2. check whether the main core components of the system are normal, including system switches, contactors, etc. are normal</li> <li>3. check whether the system air inlet and outlet, and air ducts are normal, if there is blockage and congestion, needs to clean up in time</li> </ol>	<p>Once every 6 month</p>
<p>Charge and Discharge Maintenance</p>	<p>Use light load and shallow charge/discharge to check whether the SOC, SOH status of the battery is normal (using the upper computer software to read); it is recommended that the depth of discharge and charge/discharge power should not exceed 20% of the rated value</p>	<p>Once every 6 month</p>

## 9 Cautions and Warranty

### 9.1 Cautions



Please read and comply with the following conditions of installation and use of the battery, incorrect installation using the battery may cause personal injury or damage to the product.

- (1) DO NOT throw the battery into water. Store batteries in a cool and dry environment.
- (2) DO NOT put the battery into fire or heat the battery, so as to avoid explosion.
- (3) Use a specialized charger, and follow the correct procedures.
- (4) DO NOT reverse positive and negative terminals, and do not connect the battery directly to AC power.
- (5) DO NOT use different manufacturers or different kinds of batteries together, and do not mix old batteries and new batteries.
- (6) DO NOT use the battery when it is hot, bulges, deforms or leaks.
- (7) DO NOT puncture the battery with nails or other sharp objects; Do not throw, stamp on or hit the battery.
- (8) DO NOT open or try to repair the battery. The warranty is invalid if the battery is repaired or disassembled.
- (9) Batteries are half charged before shipment. Don't use the battery if it's hot, bulge, or smells abnormal and so on, and report to the after-sale department immediately.
- (10) If you need to store the battery for a long time, please charge and discharge the battery every three months to ensure the best performance and the best state of charge for storage is between 50%~60%.
- (11) Please use the battery in the temperature range defined in the manual.
- (12) The state of charge of batteries is 50% before shipment, please charge the battery before using.

### 9.2 Description of Warranty

During the valid warranty period of the product, any problems such as product damage or functional failure caused by non-human or intentional damage will enjoy our free repair and replacement services. Customers need to provide a valid purchase invoice or related product warranty information. We have the right to refuse to provide related services if no valid proof can be provided.

# Smarty **ZETARA**



Smarty Zetara Power System Co.,Ltd

**APP Name: Lux Power Monitor**  
Available in Google play / Apple APP store



Android APP



IOS APP

Your installer need to **register a monitor account** on the monitor system and **set wifi password** for wifi module **before** using Luxpower monitor system

**1. Register an account**

**Step1.**  
Visit <http://server.luxpowertek.com> or download the 'Lux Power Monitor' APP to register an end user account. Please contact [info@luxpowertek.com](mailto:info@luxpowertek.com) for distributor or installer account

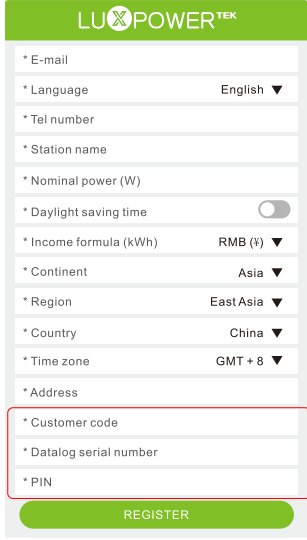
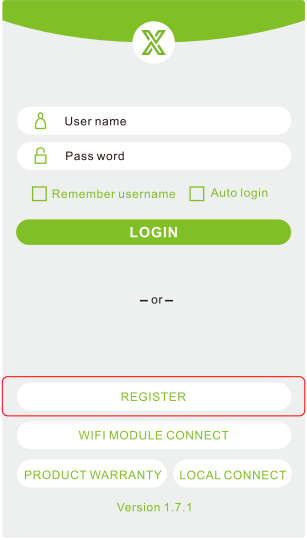
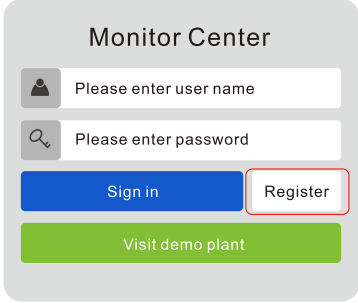

**Step2.** When you register your account, you need to fill in the following information

- a. Customer code: it is the code of distributor or installer, please contact the distributor or installer to get the customer code
- b. Datalog serial number: the serial number is attached to the wifi/LAN shell.
- c. PIN: PIN is attached to the wifi/LAN shell below the SN
- d. Income formula(kWh): Input a number which is the subsidy you get when feed one kWh energy to grid.

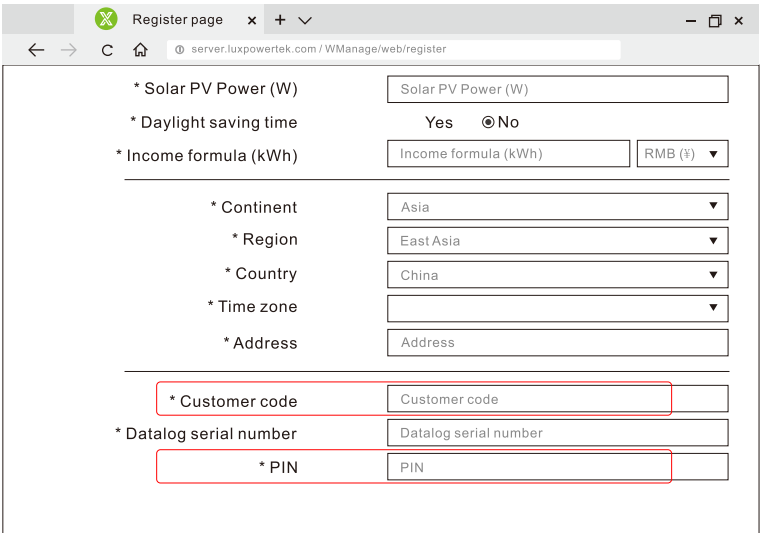

**2. Set Wifi Password**

Users can use APP or website to set home wifi password to wifi module, please follow 2.1 or 2.2 to set the password.

**2.1 Use APP to set wifi password**

**Step1.** Plug in the wifi module and Power on the inverter.



**Step2.** Wait until the INV LED on the Wifi module is solid on, then connect your phone to wifi hotspot , the hotspot name is same with wifi datalog serial number.

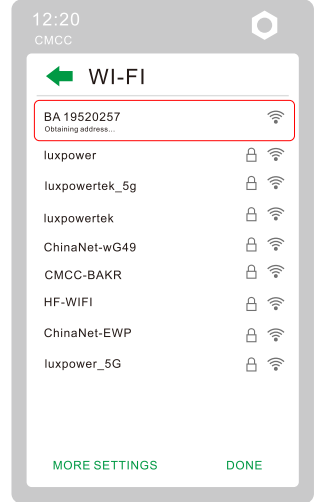

**Step3.** Open the app. Click on "WIFI MODULE CONNECT" and input or select your wireless network name (the wifi name of your router) and password.

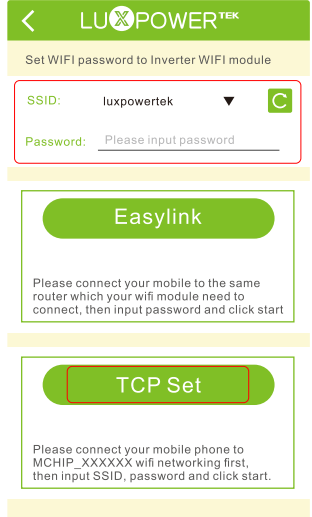
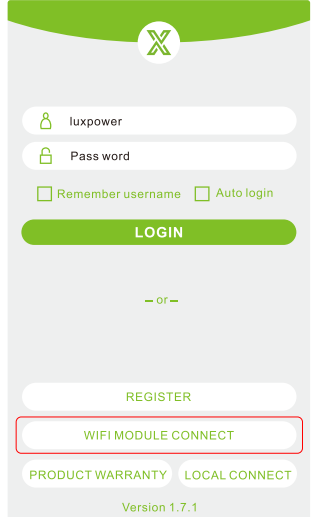

**Step4.** After you click TCP set, the wifi module will reset. The module will restart and after a few seconds the three LED will be solid, which means the inverter has connected to the server OK. Once this step is complete, you can input your account and password to login and monitor your system.

## 2.2 Use Web to Set Wifi Password

**Step1.** Power on the inverter, connect your mobile phone or laptop to the hotspot after the INV LED on the Wifi module is solid on. The name of the hotspot is the same as the serial number on the wifi module shell.

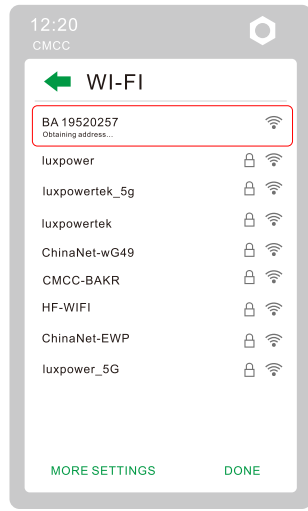

**Step2.** Enter 10.10.10.1 in the browser. Both username and password are "admin" for dialog box. After log in, select English on the right side.

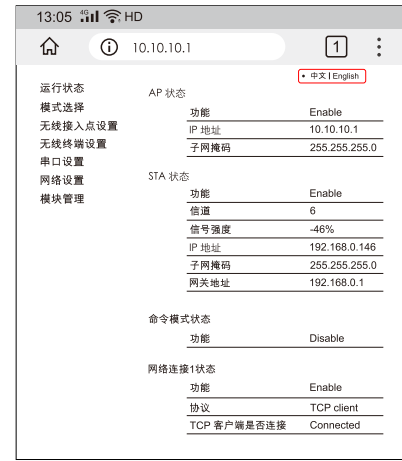
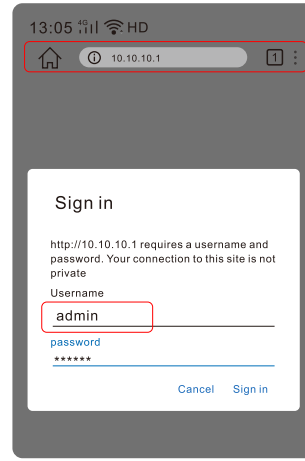

**Step3.** Go to the "Station Mode Setting" page. Click on "Scan"

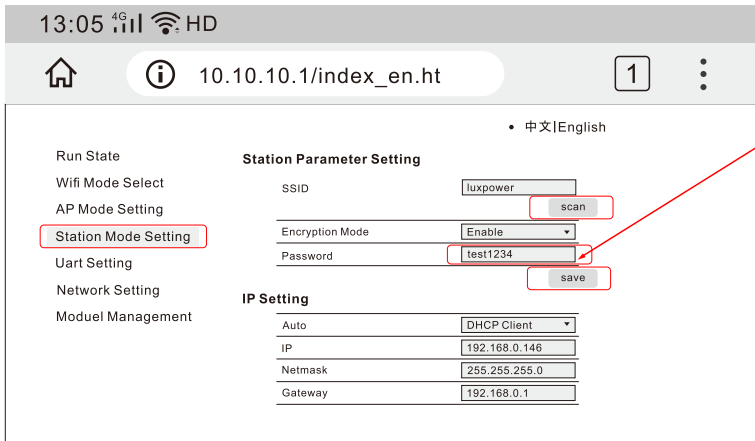

**Step4.** Select the wifi network you want to connect to and the click "OK". Input wifi password , click "Save".

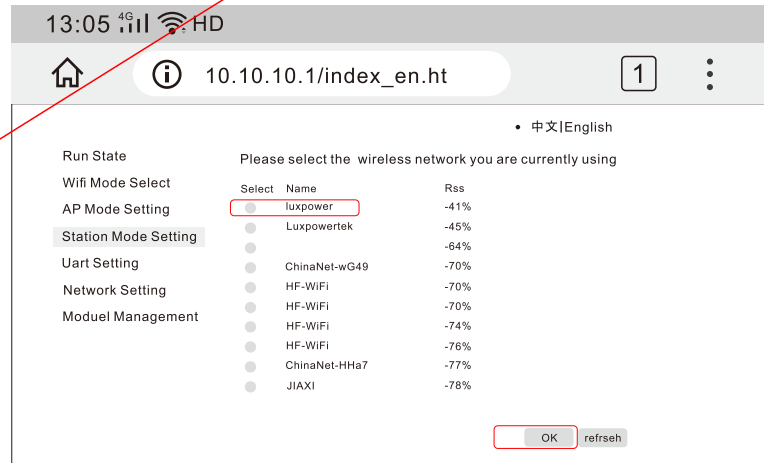

**Step5.** After saving, restart the module. After you set the right password, three light will be solid on, which means inverters has connect to server OK. Then you can input your account and password to login and monitor your system.

## 3. Use Lux Power Monitor for Local Monitor and Setting

If there is no wifi signal at the station, users can use local function to monitor or set the system.

**Step1.** Download Lux Power Monitor APP

**Step2.** Connect your mobile to wifi hotspot after the INV LED on the Wifi module is solid on. The name of the hotspot is the same as the serial number on the wifi module shell.

**Step3.** Click "Local Connect", then you can monitor and set the system

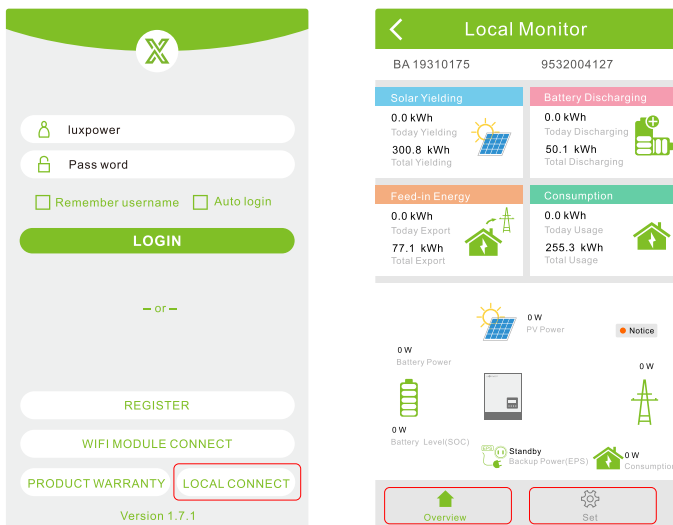

## Q&A

Q: Why does the middle light of wifi module is flashing?

A: After set the right password of wifi, three lights should be solid on, if it is still flashing, please

(1) Make sure you have set the right password and the wifi is good, you can use your mobile connect to wifi hotspot and visit website 10.10.10.1 to check, the login user name and password are both 'admin', the TCP client state should be 'connected' as show in the picture, otherwise check your wifi name and password.

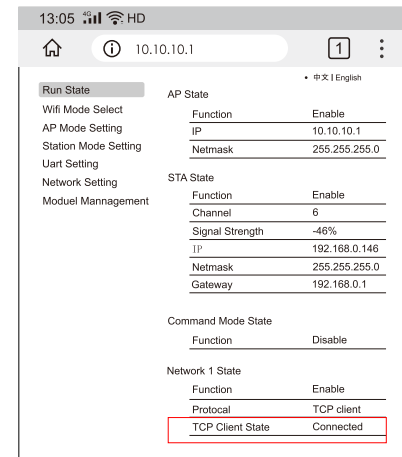

(2) You should add the datalog to the system **before** setting the password, this datalog is added to the system automatically when first time you register and input the wifi SN and PIN. If you have more than one datalog, please visit server.luxpowertek.com and login, go to 'Configuration' -> 'Datalogs' -> '+Add Datalog' to add this datalog to your existing station. After add the datalog, restart the wifi module by plug out and plug in.

